

**ITAL MACHINERY**

MACCHINA ITALIANA



**BITUMEN  
RELAY TANKER**

**Bitumen Relay Tanker is the most versatile and functional solution with its various capacities according to your requirements and optional heating and pumping systems, for hauling bitumen, PMB, emulsion and other similar materials.**

## **MAIN FEATURES**

---

- ◆ **Tank capacity** from 20.000 liter up to 40.000 liter depending on vehicle dimensions.
- ◆ **Depends on request**, different types of relay tankers with pump and burner are available.
- ◆ **For easy filling**, dual manhole option on front and back of tank and special heat resistant ball type discharge valve for Pumpless models.



**BITUMEN RELAY TANKER**

**ITAL MACHINERY**

MACCHINA ITALIANA

## MAIN FEATURES

- ◆ **In pump integrated** Bitumen Relay Tanker models, by the virtue of a 4-way valve, bidirectional discharge, tank filling and circulation within the tank made possible. Additionally, economic piping cleaning is available.
- ◆ **Diesel burner** with thermostatic control system (capacity between 14-26kg/h) for heated types of relay tanker.
- ◆ **Optional:** agitator system for PMB transfers.
- ◆ **Optional:** Compatible design with surface stabilizers such an Bomag MPH.

BITUMEN RELAY TANKER

ITAL MACHINERY

MACCHINA ITALIANA





# PRODUCT OVERVIEW - FLOW CHART

---

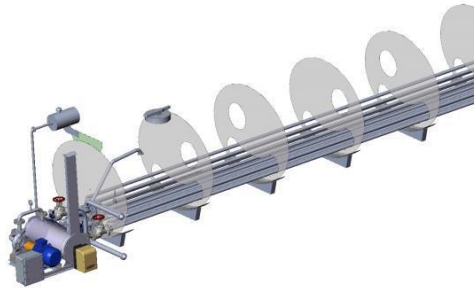
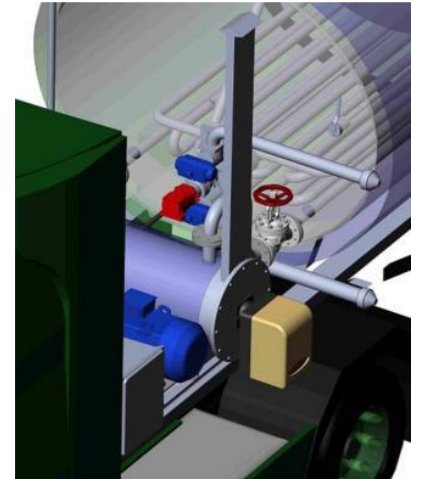
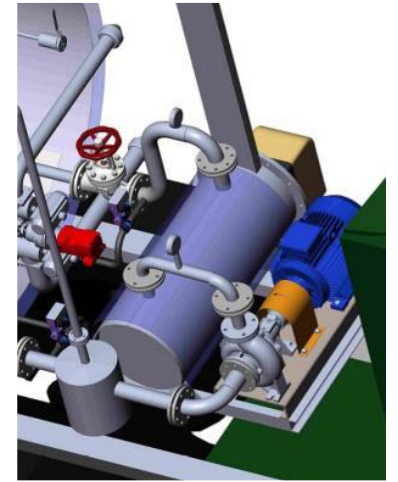
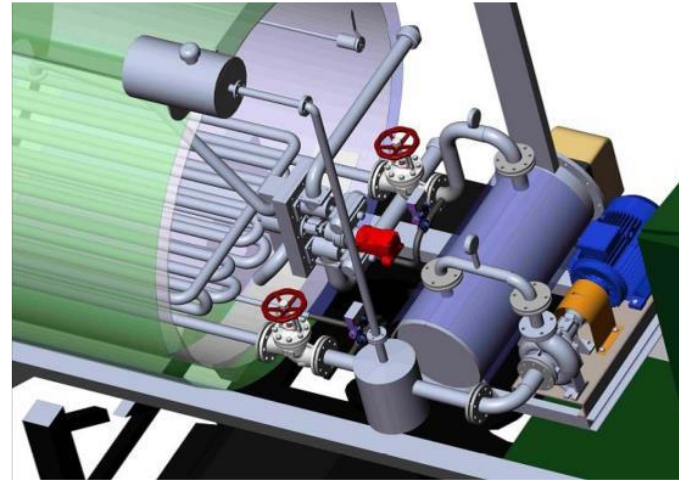
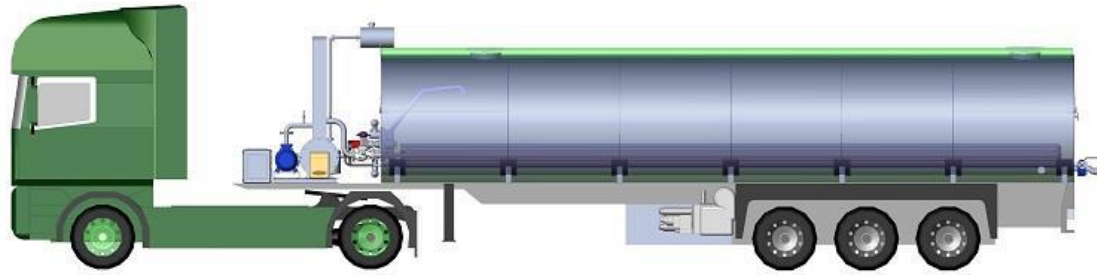

## CONTACT US

---



[italmachinery.com.ua](http://italmachinery.com.ua)



[sales@italmachinery.com.ua](mailto:sales@italmachinery.com.ua)



+38 (067) 271 61 61

+38 (067) 371 61 61

+38 (067) 801 77 00

+38 (096) 449 32 08



[facebook.com/italmachinery](https://facebook.com/italmachinery)



[@italmachinery](https://instagram.com/italmachinery)



[Ital Machinery](https://YouTube.com/ItalMachinery)

**ITAL MACHINERY**  
MACCHINA ITALIANA

